

**THIS BULLETIN IS FAA APPROVED FOR ENGINEERING DESIGN**

**SUBJECT:** Mooney M20TN (Acclaim) Aircraft with KELLY AEROSPACE TURBOCHARGER(S)

**MODELS/ SN M20TN (ACCLAIM):**

**AFFECTED:** 31-0039, 31-0042, 31-0044, 31-0046, 31-0047, 31-0049, 31-0050, 31-0052, 31-0053, 31-0056, 31-0057

**TIME OF COMPLIANCE:** MANDATORY - BEFORE NEXT FLIGHT

**INTRODUCTION:** This Service Bulletin is written in conjunction with Teledyne Continental Motors (TCM) Service Bulletin MSB07- 4 and Kelly Aerospace Service Bulletins 023 & 027 (Attached). This Service Bulletin is to remove and replace the specified turbocharger(s) (TCM P/N 646677) from Mooney Aircraft M20TN (Acclaim) in accordance with attached TCM/Kelly Aerospace Service Bulletins.

**INSTRUCTIONS:** **Read entire procedures before beginning work.**

- 1-1. Turn master switch - OFF
- 1-2. Remove top and bottom cowling per instructions provided in Chapter 71-10-00 of applicable MAC aircraft Service & Maintenance Manual.
- 1-3. Loosen hose clamp(s) on compressor discharge and disconnect it from turbocharger(s).
- 1-4. Drain oil from engine and remove filter per instructions provided in Chapter 79-00-00 of applicable MAC aircraft Service & Maintenance Manual.
- 1-5. Remove safety wire and exhaust V-Band Clamp (P/N 657198) attaching to exhaust side of turbocharger(s). (refer to Figure M20-299-1)
- 1-6. Loosen hose clamps attaching intercooler tube to top of turbocharger(s) (refer to Figure M20-299-2 & 3).

**NOTE:**

**Upon replacement of the turbocharger, it is recommended that the inlet and outlet oil lines and drain can, be flushed. Change the oil and oil filter per instructions provided in Chapter 79-00-00 of applicable MAC aircraft Service & Maintenance Manual.**

- 1-7. Remove upper oil inlet line attaching to top of turbocharger(s) (refer to Figure M20-299-1).
  - a.) If oil inlet adapter is not installed on new Turbocharger(s) you must remove the old adapter and hardware and install it on the new Turbocharger(s) using new gasket(s) (P/N 652100). Install per instructions provided in Chapter 17 of applicable TCM aircraft Engine Maintenance & Overhaul Manual.
- 1-8. Remove lower oil drain line attaching to bottom of turbocharger(s) (refer to Figure M20-299-1).
  - a.) If oil drain adapter is not installed on new Turbocharger(s) you must remove the old adapter and hardware and install it on the new Turbocharger(s) using new gasket(s) (P/N 652100). Install per instructions provided in Chapter 17 of applicable TCM aircraft Engine Maintenance & Overhaul Manual.
- 1-9. Remove hardware attaching turbocharger(s) bracket to airframe (refer to Figure M20-299-1).
- 1-10. Remove and discard (4) bolts, washers, and lock nuts mounting turbocharger(s) to exhaust system, and remove turbocharger(s) (refer to Figure M20-299-1).



**THIS BULLETIN IS FAA APPROVED FOR ENGINEERING DESIGN**

**NOTE:**

**Upon replacement of the turbocharger(s), it may be necessary to remove original mounting bracket and install on new Turbocharger(s) (if not equipped).**

- 1-11.** Install turbocharger(s) (clock position as factory installed) with new flange gasket (P/N 636465) (4) bolts (P/N NAS1006-12A), (8) washers (P/N NAS1587-6), (4) lock nuts (P/N NAS1021C6) per side, mounting turbocharger(s) to exhaust system. Torque per instructions provided in Chapter 17 of applicable TCM aircraft Engine Maintenance & Overhaul Manual. (refer to Figure M20-299-1, 2 & 3)
- 1-12.** Install hardware attaching turbocharger(s) bracket to airframe and torque per instructions provided in Chapter 17 of applicable TCM aircraft Engine Maintenance & Overhaul Manual.
- 1-13.** Install and tighten upper oil inlet line attaching to top of turbocharger(s) (refer to Figure M20-299-1)
  - a.)** If oil inlet adapter was not installed on new Turbocharger(s) you must remove the old adapter and hardware and install it on the new Turbocharger(s) using new gasket(s) (P/N 652100). Install per instructions provided in Chapter 17 of applicable TCM aircraft Engine Maintenance & Overhaul Manual.
- 1-14.** Install and tighten lower oil drain line attaching to top of turbocharger(s) (refer to Figure M20-299-1)
  - a.)** If oil drain adapter was not installed on new Turbocharger(s) you must remove the old adapter and hardware and install it on the new Turbocharger(s) using new gasket(s) (P/N 652100). Install per instructions provided in Chapter 17 of applicable TCM aircraft Engine Maintenance & Overhaul Manual.
- 1-15.** Install new exhaust V-Band Clamp (P/N 657198) and safety wire (P/N MS20995C32) to exhaust side of turbocharger(s) per instructions provided in Chapter 81-30-00 of applicable MAC aircraft Service & Maintenance Manual. Also refer to instructions provided in Chapter 17 of applicable TCM aircraft Engine Maintenance & Overhaul Manual. (refer to Figure M20-299-1, 2 & 3)
- 1-16.** Install and tighten hose clamp(s) on compressor discharge to turbocharger(s) (refer to Figure M20-299-2 & 3)
- 1-17.** Install new oil filter (P/N 649923) and fill with fresh oil per instructions provided in Chapter 79-00-00 of applicable MAC aircraft Service & Maintenance Manual.
- 1-18.** Run engine and check for leaks (If leaks are present repair as required).
- 1-19.** Re-install top and bottom cowling per instructions provided in Chapter 71-10-00 of applicable MAC aircraft Service & Maintenance Manual.
- 1-20.** Complete log book entry.
- 1-21.** Return aircraft to service.
- 1-22.** Procedure complete.



**THIS BULLETIN IS FAA APPROVED FOR ENGINEERING DESIGN**

**WARRANTY:** Mooney Airplane Company, Inc. will warrant labor (approximately 6 hours if one turbo is replaced and 8 hours if both turbos are replaced), when done in accordance with the procedures of this Service Bulletin for aircraft currently covered under the Mooney Airplane Company, Inc. factory warranty program.

**REFERENCE DATA:** MAC Service & Maintenance Manuals (applicable A/C), Kelly Aerospace Service Bulletin 027, TCM aircraft Engine Maintenance & Overhaul Manual (M- 18).

**PARTS LIST:** Mooney International Corporation, Inc., Parts Kits:

**M20-299-001: (Single-Turbocharger Replacement)**

<u>Item</u>	<u>P/N</u>	<u>Description</u>	<u>Qty</u>
1.	646677	Turbocharger	1
2.	636465	Gasket, Turbocharger Flange	1
3.	657198	Clamp, Turbocharger V-Band	1
4.	652100	Gasket, Turbocharger Inlet Oil	1
5.	652101	Gasket, Turbocharger Outlet Oil Drain	1
6.	MS20995C32	Safety Wire (V- Band Clamp)	36"
7.	NAS1006-12A	Bolt	4
8.	NAS1587-6	Washer	8
9.	NAS1021C6	Loc Nut	4
10.	CH48109- 1	Oil Filter (TCM P/N 649923)	1
11.	TCM (Spec MHS- 24)	Engine Oil (Quarts)	8

**M20-299-002: (Dual-Turbocharger Replacement)**

<u>Item</u>	<u>P/N</u>	<u>Description</u>	<u>Qty</u>
1.	646677	Turbocharger	2
2.	636465	Gasket, Turbocharger Flange	2
3.	657198	Clamp, Turbocharger V-Band	2
4.	652100	Gasket, Turbocharger Inlet Oil	2
5.	652101	Gasket, Turbocharger Outlet Oil Drain	2
6.	MS20995C32	Safety Wire (V- Band Clamp)	36"
7.	NAS1006-12A	Bolt	8
8.	NAS1587-6	Washer	16
9.	NAS1021C6	Loc Nut	8
10.	CH48109- 1	Oil Filter (TCM P/N 649923)	1
11.	TCM (Spec MHS- 24)	Engine Oil (Quarts)	8



THIS BULLETIN IS FAA APPROVED FOR ENGINEERING DESIGN

**NOTE:** Refer to TCM aircraft Engine Maintenance & Overhaul Manual (M- 18) and applicable MAC aircraft Service & Maintenance Manual

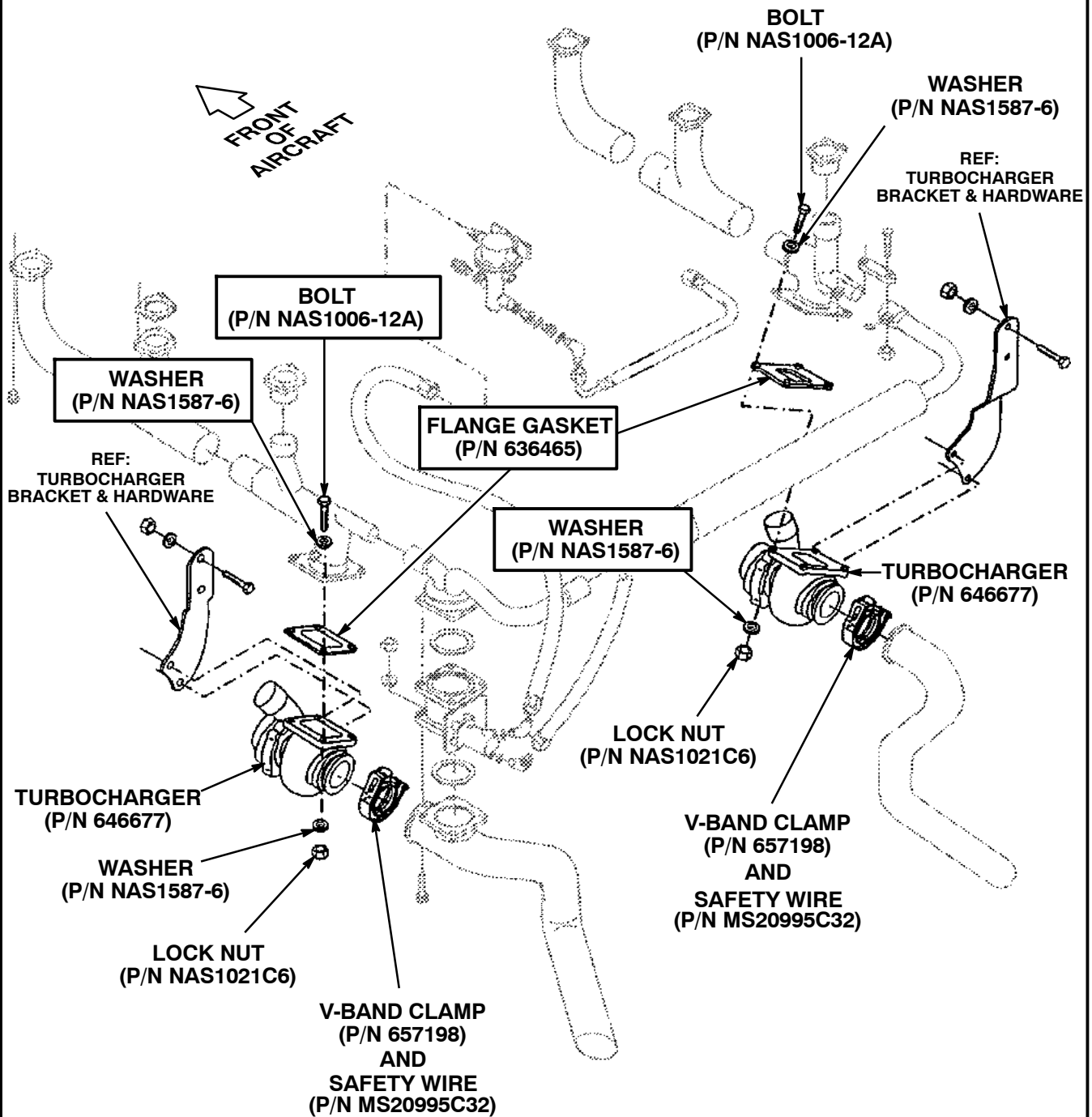

Figure SB M20-299-1 - Turbocharger Hardware and Installation



THIS BULLETIN IS FAA APPROVED FOR ENGINEERING DESIGN

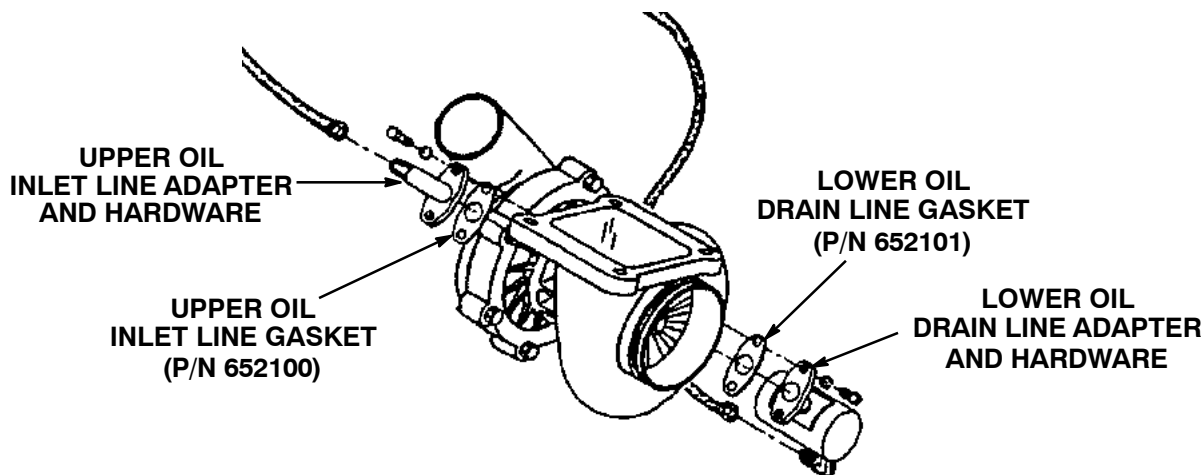
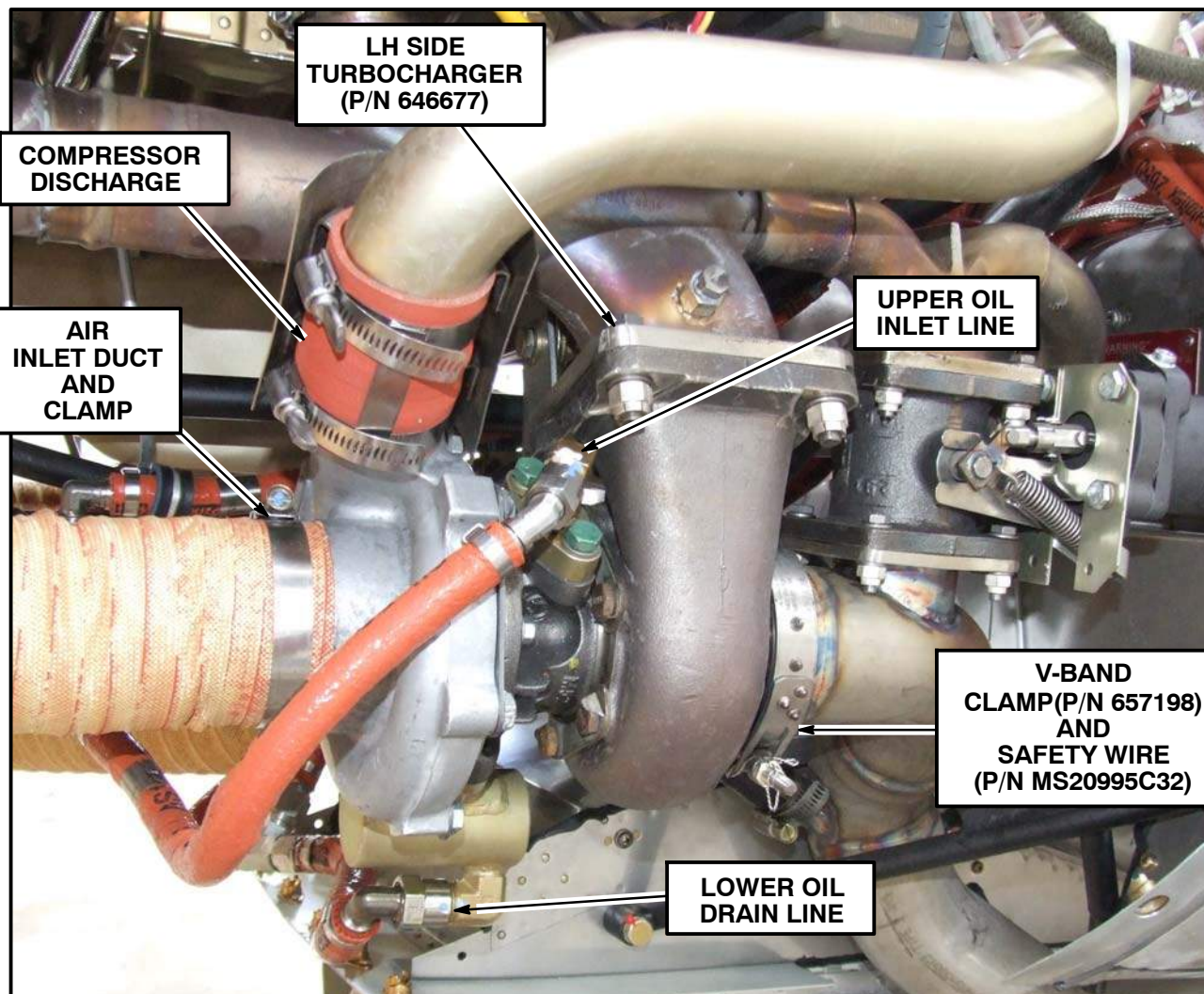

Figure SB M20-299-2 - LH Turbocharger Installed



THIS BULLETIN IS FAA APPROVED FOR ENGINEERING DESIGN

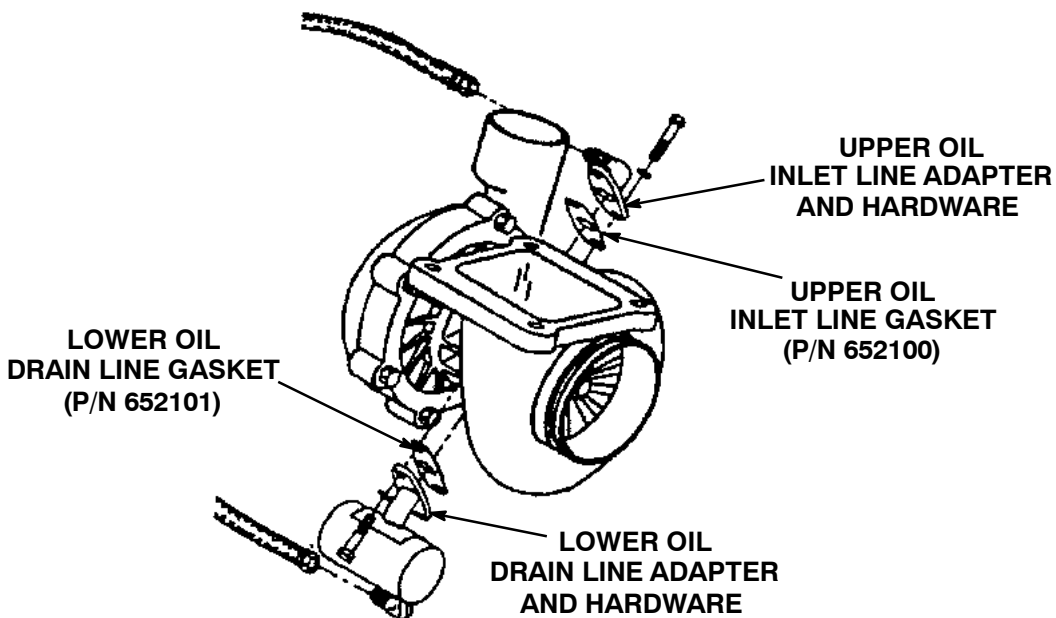
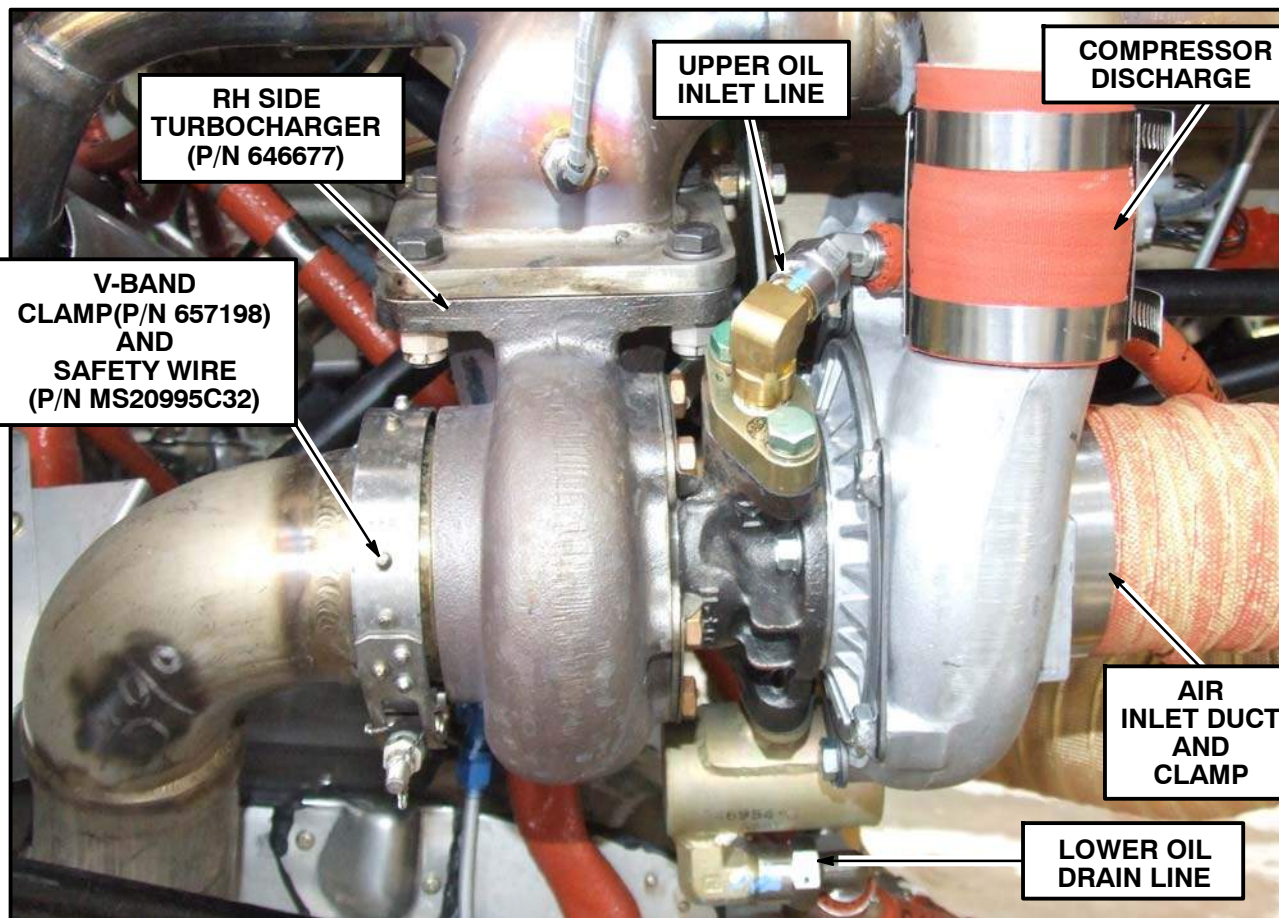

Figure SB M20-299-3 - RH Turbocharger Installed



## Power Systems

PO Box 273 • Fort Deposit, AL 36032  
(334) 227-8306 • Fax: (334) 227-8596

# Service Bulletin

The technical content of this letter is FAA Approved

Bulletin No. 23

Issue Date: Feb. 8, 2006

## TURBOCHARGER SYSTEM OPERATIONAL TESTS

### INTRODUCTION:

All overhauled or repaired turbochargers must be tested according to the Kelly Aerospace Power Systems Turbocharger Overhaul & Maintenance Manual (P/N 400600-0000) prior to returning the aircraft/rotorcraft to service. While many turbochargers are overhauled or repaired at a facility where testing of the aircraft/rotorcraft is possible, many are exchanged with units off the shelf or are placed on the shelf as inventory. Overhaul shops or facilities that are unable to test the overhauled or repaired turbochargers on the aircraft/rotorcraft are required inform their customers that the Turbocharger System Operational Test must be performed prior to return to service. Since the Turbocharger Overhaul & Maintenance Manual may not be available at all aviation service centers, the Turbocharger System Operational Test has been duplicated herein.

This Service Bulletin is being issued to assure that any Kelly Aerospace Power Systems overhauled or repaired turbocharger is tested per Turbocharger System Operational Tests as found in the Overhaul & Maintenance manual.

### COMPLIANCE:

Whenever a Kelly Aerospace Power Systems overhauled or repaired turbocharger is installed on an aircraft or rotorcraft.

### EFFECTIVITY:

Any aircraft or rotorcraft utilizing Kelly Aerospace Power Systems turbocharger, which has been overhauled or repaired (Including those units made by Garrett/AirResearch, AlliedSignal Garrett/Honeywell, Consolidated Fuels, Rajay/RotoMaster, and Rajay).

### PROCEDURE:

Perform the following operational checks on the aircraft/rotorcraft before it is returned to service.

### TURBOCHARGER SYSTEM OPERATIONAL TEST:

#### CAUTION:

The operational checks herein are generic in nature but will apply to most turbocharged aircraft. Should these procedures conflict in any way with those in the aircraft/rotorcraft AFM or POH, the procedures in the AFM or POH must be used.

#### WARNING:

Prior to turning over or starting the engine, make sure that all equipment, staff or other persons are clear of the propeller or rotors and testing area.

## **PROCEDURE: (cont'd)**

### **PRE-LUBRICATION OF TURBOCHARGER:**

All overhauled or repaired turbochargers must be pre-lubricated prior to installation and prior to engine start. Preheat engine in extremely cold conditions.

- A. Just prior to mounting, prime the turbocharger with engine oil by filling the oil inlet of the turbocharger bearing housing and rotating the T-wheel by hand to coat the bearings.
- B. Make sure the oil inlet line is clean and free of obstructions. Crank the engine over with the ignition off and the fuel in the idle cut off position until oil comes out of the turbocharger drain line. Connect the drain line. Start the engine and observe oil pressure. Should oil pressure not rise to 10 psi within 5 seconds, shut engine down and investigate the cause. When proper oil pressure is reached, idle the engine for 5 minutes minimum. Shut engine down and check for oil leaks.

### **GROUND RUN AND SETUP:**

Perform a ground run-up to check basic performance and integrity of the turbocharging system. Prior to accomplishing this procedure, check the appropriate aircraft service or maintenance manual for the ground run procedures and check the appropriate AFM or POH for the applicable preflight procedures. Should these tests reveal improper conditions, additional information on troubleshooting, may be found in the Kelly Aerospace, Aircraft Turbocharger and Control Systems Reference With Troubleshooting Guide Handbook, P/N 400888-0000.

#### **WARNING:**

Prior to starting and running the engine, make sure that an appropriate testing area is selected and that all equipment, staff or other persons are clear of the propeller or rotors.

#### **CAUTION:**

It is not advisable to perform the ground run-up or Pre-lubrication on an overhauled or repaired turbocharger in extremely cold weather conditions. Preheat the aircraft prior to accomplishing these tests.

- A. Before beginning these tests, read the applicable sections of the appropriate service or maintenance manuals as well as the AFM and POH regarding run up procedures. Should any step herein conflict from the AFM or POH procedures, use that information.
- B. Start the engine and observe oil pressure. Should oil pressure not rise to 10 psi within 5 seconds, shut engine down and investigate the cause. When proper oil pressure is reached, idle the engine for 5 minutes. Allow the oil temperature to stabilize at 120 deg. F (or as called out in the AFM or POH) and the oil pressure above 10 psi. *Stay within the minimum and maximum limitations!*

#### **Note:**

Blue or white smoke may appear from the exhaust during initial start and run up. Unless the smoke is extreme or appears in combination with an oil pressure drop, it can be considered normal. Lubricants used in assembly may make light smoke for up to 30 minutes operation.



## GROUND RUN AND SETUP: (CONT'D)

- C. Advance the throttle slowly in 500 RPM increments until takeoff power is reached. Pause at each RPM step and allow the engine to stabilize (the turbocharger will lag slightly). At each RPM step, observe oil pressure, oil temperature, TIT/EGT, and manifold pressure (MAP). These indications should not fluctuate but remain steady. Oil pressure above idle should be a minimum of 30 psi. Take care not to overboost the engine when approaching takeoff power, throttle movement at power is sensitive. Consult the applicable AFM or POH and determine and record TIT/EGT and MAP at takeoff power.
- D. Retard the throttle slowly to idle. Great care should be taken not to reduce power rapidly. For 400 series (Garrett style) turbochargers, operate the engine at idle for 3 to 5 minutes to allow the turbine wheel to slow down. No idle time is required on 600 series (Rajay/RotoMaster style) turbochargers.
- E. Shut down the engine and inspect for oil leaks and general security. *If installed, tap V-band coupling to assure seating and re-torque nut. (See Table 1 page 5)* If proper TIT/EGT or MAP was not achieved, investigate cause. Compare all engine parameters to the requirements in the AFM or POH and if necessary, perform an engine setup per the applicable aircraft service or maintenance manual. If required, repeat this check.

## OPERATIONAL FLIGHT TEST:

### WARNING:

The operational flight test must be performed by an appropriately rated, current pilot familiar with the aircraft/rotorcraft and the requirements and limitations of the AFM or POH.

Perform a flight test to confirm operation of the turbocharging system. While there are many types of turbocharging systems, they can be categorized as Manual or Automatic.

**MANUAL SYSTEMS:** The most basic form of manual control is the fixed bleed system which allows exhaust gas to continuously escape through an orifice of predetermined size. The size of the orifice determines the critical altitude of the engine. More complex manual systems will have a method to adjust the wastegate through use of a vernier cable. These systems may or may not incorporate a pressure relief valve so great care must be taken not to overboost the engine.

**AUTOMATIC SYSTEMS:** The automatic systems that control turbocharger operation use air pressure sensors installed at various points in the induction system. They in turn will cause changes to the oil pressure that controls the position of the wastegate. There are many different systems therefore, it is very important that the mechanic and pilot understand what manifold pressures he should expect when full throttle is applied for takeoff.

### PRECAUTIONS:

1. Do not exceed the red-line temperature limitations during takeoff, climb and max performance cruise power operation.
2. Keep the cylinder head temperature (CHT), Oil temperature, turbine inlet temperature (TIT or EGT) below the max limits stated in the aircraft AFM or POH .
3. Whenever mixture is adjusted, rich or lean, it should be done slowly.
3. Unless it conflicts with the aircraft AFM or POH, always return the mixture slowly to full rich before increasing the power setting.
4. At all times, caution must be taken not to shock cool the cylinders. Do not allow a CHT change of more than 50 deg. F per minute.
5. The throttle(s) must be operated smoothly or the engine(s) will surge. Smooth and steady operation of the mixture control will assure that TIT/EGT limits are not exceeded.

## **OPERATIONAL FLIGHT TEST: (CONT'D)**

Prepare the aircraft for the test flight. Perform a preflight and run up according to the appropriate aircraft AFM or POH. Proceed with normal takeoff. Due to the special nature of rotorcraft, the flight test may be substantially different, however a basic check of performance per the AFM or POH must be applied.

- A. TAKEOFF: Using AFM or POH data, establish a max power takeoff and record engine parameters with close attention to MAP. If applicable reduce power within time limits. Manual systems will require constant attention. Extreme care must be taken not to overboost the engine. Should an overboost occur, refer to the latest revision of Lycoming Service Bulletin 369 or Teledyne Continental Motors Service Bulletin 67-12.
- B. CLIMB: Using AFM or POH data, establish max power climb, record the engine parameters each 1000 feet, with close attention to MAP and TIT/EGT. Remember, to increase power, enrich the mixture, increase RPM, and then MAP. Maintain a consistent climb until critical altitude is reached, however do not exceed max CHT. Without changing power setting, climb above critical and note that MAP decreases.
- C. CRUISE: Using AFM or POH data, establish a max performance cruise and then an economy cruise setting. Record engine parameters, fuel flow, and aircraft speed. Compare to the AFM or POH published information.
- D. DESCENT AND LANDING: Using AFM or POH data, descend and land. Please note, manual systems will require constant attention. For decent, do not pull throttle(s) back rapidly, do not allow a CHT change of more than 50 deg. F per minute, and remember to decrease power decrease MAP and then RPM. For landing, follow the procedures in the AFM or POH.

## **RETURN TO SERVICE:**

After landing, determine turbocharger performance using the data recorded. Any discrepancy noted must be investigated and a remedy applied before returning the aircraft to service. In most cases, improper or low performance will be related to conditions other than the turbocharger, in order of importance, consult the aircraft service or maintenance manual, Kelly Aerospace, Aircraft Turbocharger and Control Systems Reference With Trouble-shooting Guide Handbook, P/N 400888-0000, and the Kelly Aerospace Overhaul manual. If the operational test procedures are satisfactory, make the appropriate logbook entries and return the aircraft to service.

## **DISPOSITION OF INVENTORY:**

Any turbocharger which has been overhauled or repaired and placed in inventory must be delivered with a copy of this Service Bulletin. Download the Service Bulletin file at <http://www.kellyaerospace.com/>, select service bulletins and turbocharger system components. Additional copies may be made from the file.

## **CONTACT INFORMATION:**

If you have any questions concerning the instructions in this service bulletin, please contact Kelly Aerospace Power Systems Technical Support at 888-461-6077.

Questions concerning aircraft or rotorcraft service or operation must be forwarded to the applicable manufacturer of that product.

Table 1 - V-Band Clamp Torque

Clamp P/N*	Diameter mm	Diameter in	Nut Torque
400500-925	235.0	9.25	110-130 in/lbs
400720-775	196.9	7.75	40-60 in/lbs
400720-685	174.0	6.85	40-60 in/lbs
446397-775	196.9	7.75	110-130 in/lbs

All KAPS 600 series (Rajay, RotoMaster)

CF600391-00	ALL	ALL	15-20 in/lbs
-------------	-----	-----	--------------

\* Part number etched on strap or check diameter.

## TURBOCHARGER INSPECTION AND REPLACEMENT

### INTRODUCTION:

It has come to the attention of Kelly Aerospace Power Systems of a disabled turbocharger where the turbine and compressor wheel shaft bearing journals were pushed inward and damaged on a part number 466304-0003 turbocharger. Examination of the damage revealed that a conical vibration along the turbine wheel and shaft assembly was the principal source of the damage. Investigation of the cause has determined that the turbine wheel shaft assembly for this particular turbocharger may have been improperly balanced. Continued operation with a turbine wheel shaft imbalance may result in the separation of the turbine wheel head from the shaft rendering the turbocharger inoperative and may result in the partial or total loss of engine power.

This Service Bulletin is being issued to mandate the replacement of affected turbochargers P/N 466304-0003 (TCM P/N 646677) as listed by serial number in the table below.

### COMPLIANCE:

Prior to next flight. *If the turbocharger replacement can not be accomplished on site, a ferry permit is required to deliver the aircraft to a suitable facility for repair. (To determine if the turbocharger is suitable to apply for a ferry permit, see visual inspection below.)*

### EFFECTIVITY:

Any aircraft utilizing a Teledyne Continental Motors engine with a Kelly Aerospace Power Systems turbocharger P/N 466304-0003 (TCM P/N 646677) with the serial numbers listed below.

**Suspect Serial Numbers**

KBL00782	KBL00789	KBL00797	KCL00588	KCL00627	KCL00639	KCL00724
KBL00783	KBL00790	KCL00581	KCL00589	KCL00629	KCL00717	KCL00725
KBL00784	KBL00792	KCL00582	KCL00590	KCL00631	KCL00718	KCL00726
KBL00785	KBL00793	KCL00583	KCL00621	KCL00633	KCL00719	KCL00727
KBL00786	KBL00794	KCL00584	KCL00623	KCL00636	KCL00720	KCL00728
KBL00787	KBL00795	KCL00585	KCL00625	KCL00637	KCL00721	KCL00730
KBL00788	KBL00796	KCL00587	KCL00626	KCL00638	KCL00722	KCL00731

## PROCEDURE:

### CAUTION:

This procedure must be performed by competent and qualified personnel familiar with engine and airframe maintenance activities that are specific to turbocharged aircraft.

### CAUTION:

Do not depend on this Service Bulletin for gaining access to the aircraft or engine. This will require that you use the applicable manufacturers maintenance manuals or service instructions. In addition, any preflight or inflight operational checks require use of the appropriate AFM or POH.

This procedure has two steps. First, the visual inspection; the purpose is to determine if the turbocharger may be used and is suitable for the relocation of the aircraft. Second, the basic instructions to remove, replace, and check the turbocharger. *See caution above. See Table on page 1 for serial numbers affected.*

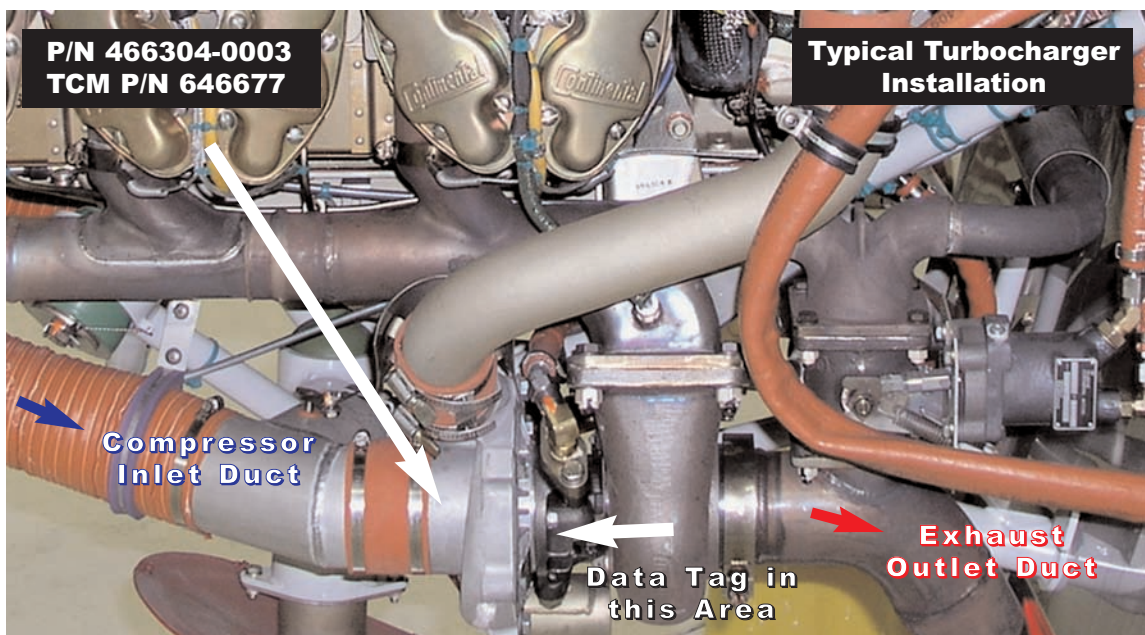
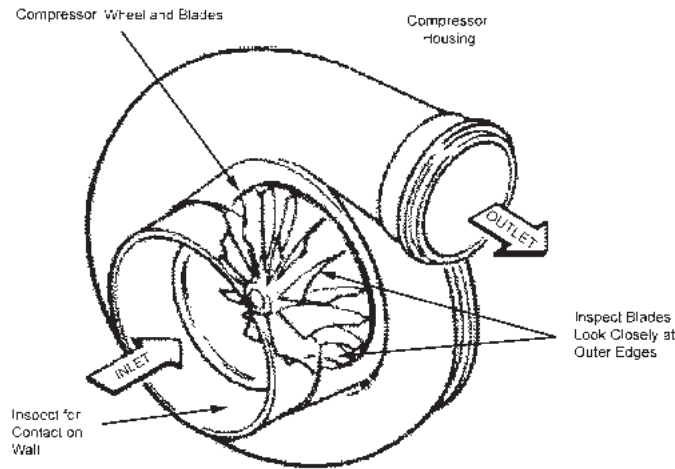

Figure 1 - Turbocharger Installation

## VISUAL INSPECTION:

1. Access the aircraft turbochargers in accordance with the instructions in the aircraft maintenance manual.
2. Remove the compressor inlet ducts to expose the compressor wheels (see caution above). Refer to Figure 1.
3. Visually inspect each turbocharger through the compressor inlet for any signs of contact. Look for witness marks from the impeller wheel, giving careful attention to the outer edges of the wheel blades and the inner wall of the compressor housing. Contact marks on the housing from the wheel will appear as a burnishing on the inner wall. Grooves or gouges of any sort are cause for turbocharger replacement. Utilize supplemental lighting if needed to facilitate visual inspection. Refer to Figure 2, page 3.
4. If any anomalies are noted during the visual inspection, replace the turbocharger. If nothing appears in the visual inspection, the turbocharger is suitable to submit for a ferry permit. This will allow the aircraft to be relocated to qualified facility for turbocharger replacement.



**Figure 2 - Turbocharger Inspection Points**

**TURBOCHARGER REPLACEMENT:**

1. The affected turbocharger P/N 466304-0003 (TCM P/N 646677) must be removed and replaced per the table shown on page 1. Each aircraft has two turbochargers. Check the data tag on each to identify whether the serial number of the turbocharger is one that is affected. When identification is made, remove the turbocharger from the aircraft. Removal must be in accordance with the aircraft and/or engine manufacturers maintenance manuals or service instructions. Contact the aircraft and/or engine manufacturer to determine the disposition of the suspect turbocharger and information regarding the return of the turbocharger(s). All warranty applications must be made through the aircraft and/or engine manufacturer. *Refer to Fig 1 as required.*
2. Upon replacement of the turbocharger, it is recommended that the inlet and outlet oil lines and drain can be flushed. Change the oil and oil filter in accordance with the aircraft and/or engine manufacturers maintenance manual or service instructions.
3. Utilizing the applicable aircraft and/or engine manufacturers maintenance manuals or service instructions, re-install the turbocharger assembly and connect the oil lines. Connect the turbocharger compressor inlet duct and coupling, torque the clamps to manufacturer specifications. Connect the exhaust outlet duct carefully, position and torque the “V” band clamp to manufacturer specifications. *It is critical that a new gasket be installed at the oil drain adapter and installed and torqued down properly. An oil leak in this area may result in engine oil starvation and subsequent engine failure.*

**RETURN TO SERVICE:**

**NOTE:**

Check for the latest publication issued by the applicable aircraft manufacturer regarding exact aircraft model, serial number and warranty procedures.

1. When the turbocharger has been replaced, the aircraft may now be prepared for return to service.
2. Refer to Kelly Aerospace Power Systems Service Bulletin 23 and perform the recommended turbocharger operational tests. This consists of turbocharger pre-lubrication, ground running tests, and and operational flight test. Make sure no air, exhaust, or oil leaks are present. *Service Bulletin may be viewed or downloaded online via [www.kellyaerospace.com](http://www.kellyaerospace.com).*
4. Utilizing the applicable aircraft and engine manufacturers maintenance manuals, install any portion of the aircraft removed to gain access.
5. Upon successful completion of this service bulletin per the applicable compliance time listed on page 1, make an appropriate log book entry.

**PARTS REQUIRED:**

One (1) or two (2) each, turbocharger, part number 466304-0003 (TCM P/N 646677) as required. One (1) each engine oil filter as required. Up to (4) each, turbocharger oil inlet or drain adapter gasket, part number as per the engine or aircraft manufacturers parts list. Parts must be obtained from the engine or airframe manufacturer.

**WARRANTY STATEMENT:**

The sole warranty applicable to this service publication is related to the terms and conditions in the aircraft or engine manufacturers Limited Warranty Policy. This publication does not imply or state any responsibility for the workmanship of any person or entity performing work or maintenance on the turbocharger, engine, or aircraft. All claims for warranty must be forwarded to the the airframe and/or engine manufacturer per the requirements contained in their Limited Warranty policies as applicable.

**CONTACT INFORMATION:**

If you have any questions concerning the instructions in this service bulletin, please contact Kelly Aerospace Power Systems Technical Support at 888-461-6077.

Questions concerning aircraft service or operation must be forwarded to the applicable manufacturer of that product.