



THIS BULLETIN DOES NOT CHANGE AIRCRAFT TYPE DESIGN

SUBJECT: Mooney M20U and M20V Aircraft

MODELS/ SN AFFECTED: **M20U:** 32-0002 thru 32-0005
M20V: 33-0002, 33-0004, 33-0005 and 33-0007

TIME OF COMPLIANCE: **Within next 25 hours**

INTRODUCTION: Mooney International Corporation has determined the possibility of aluminum tape covering ventilation holes in the lower LH and RH rear vent channels. This will require a 1-Time inspection and procedure (if found incorrect) for the affected aircraft.

INSTRUCTIONS: **Read entire procedures before beginning work.**

NOTE:

All work to be done in accordance with FAA AC43.13.

- 1.1. Turn the Master Switch off.
- 1.2. Loosen Aft belly panel camlocs, lower belly panel enough to disconnect marker antenna coax cable, and remove Aft belly panel. This will allow access to lower vent holes in lower fuselage channel, see Figure SBM20-333-1.
- 1.3. Remove any tape covering lower fuselage channel, if needed use long needle nose pliers, see Figure SBM20-333-1.
- 1.4. Inspect all holes for tape in lower fuselage vent channel with a mirror or bore scope. If tape is found, continue with next **STEPS**, if no tape is found, continue to **STEP 1.5**.
- 1.5. Remove tape covering holes in lower fuselage vent channel, if needed use sharp awl or suit able length rod with a sharpened end to penetrate tape, and open holes. Refer to SBM20-333-2.
- 1.6. Re-Install Aft belly fairing, connect marker antenna coax cable, and assure all camlocs are securely fastened.

NOTE:

Fill out compliance card and send by MAIL or FAX to Mooney International Corporation as indicated on the attached Compliance Card. (See Figure SBM20-333-3)

- 1.7. Return aircraft to service.
- 1.8. Procedure complete.

WARRANTY: Mooney International Corporation will warrant labor 3 hours when inspection is done in accordance with procedures of this Service Bulletin for aircraft currently covered under the Mooney International Corporation factory warranty program.

REFERENCE DATA: 1. Mooney Service and Maintenance Manual

PARTS LIST: Mooney International Corporation, Service Bulletin Parts Kit(s):

<u>Item</u>	<u>P/N</u>	<u>Description</u>	<u>Qty</u>
		N/A	



THIS BULLETIN DOES NOT CHANGE AIRCRAFT TYPE DESIGN

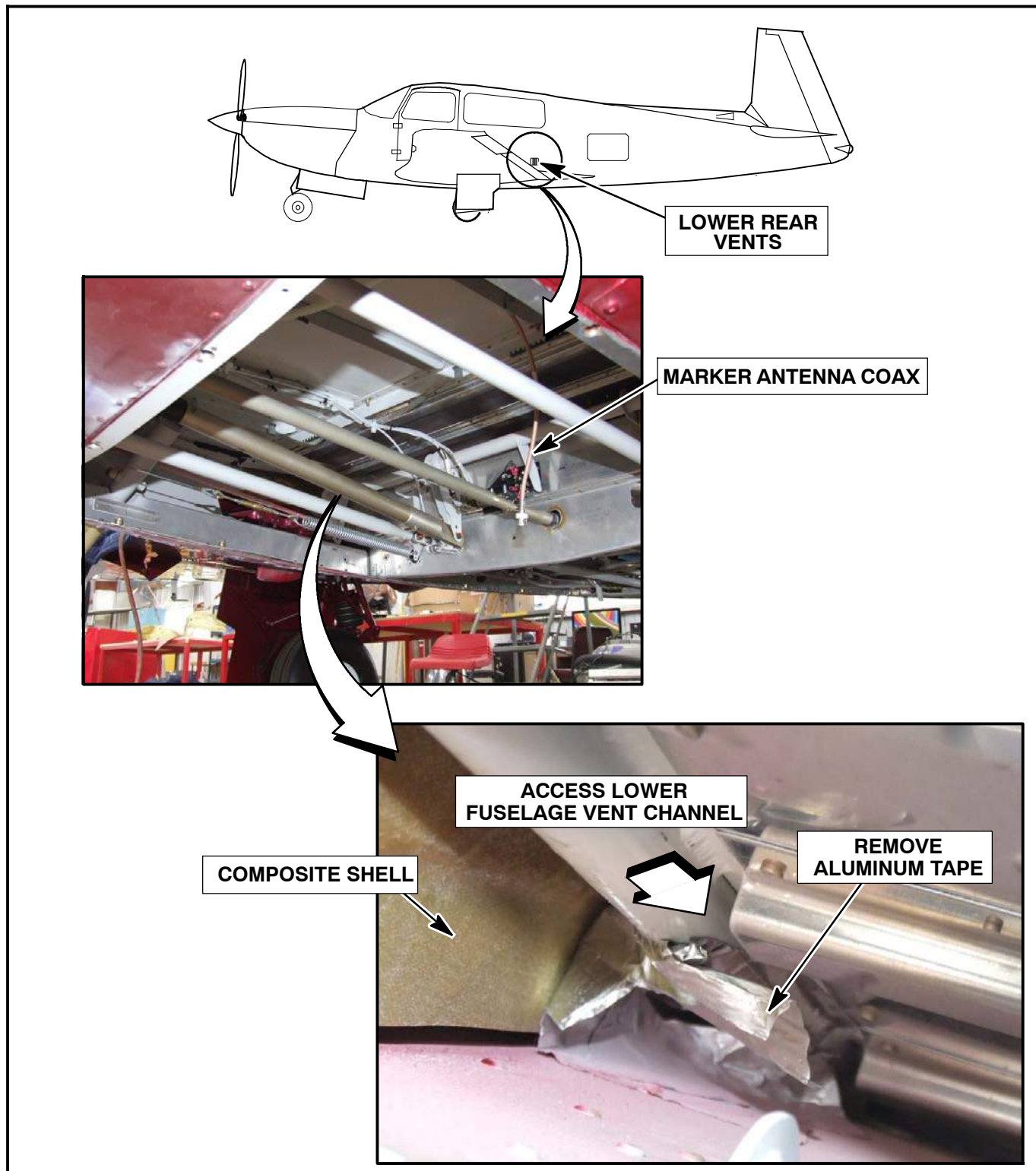

Figure SBM20-333-1 - LOWER FUSELAGE - REMOVING ALUMINUM TAPE



THIS BULLETIN DOES NOT CHANGE AIRCRAFT TYPE DESIGN

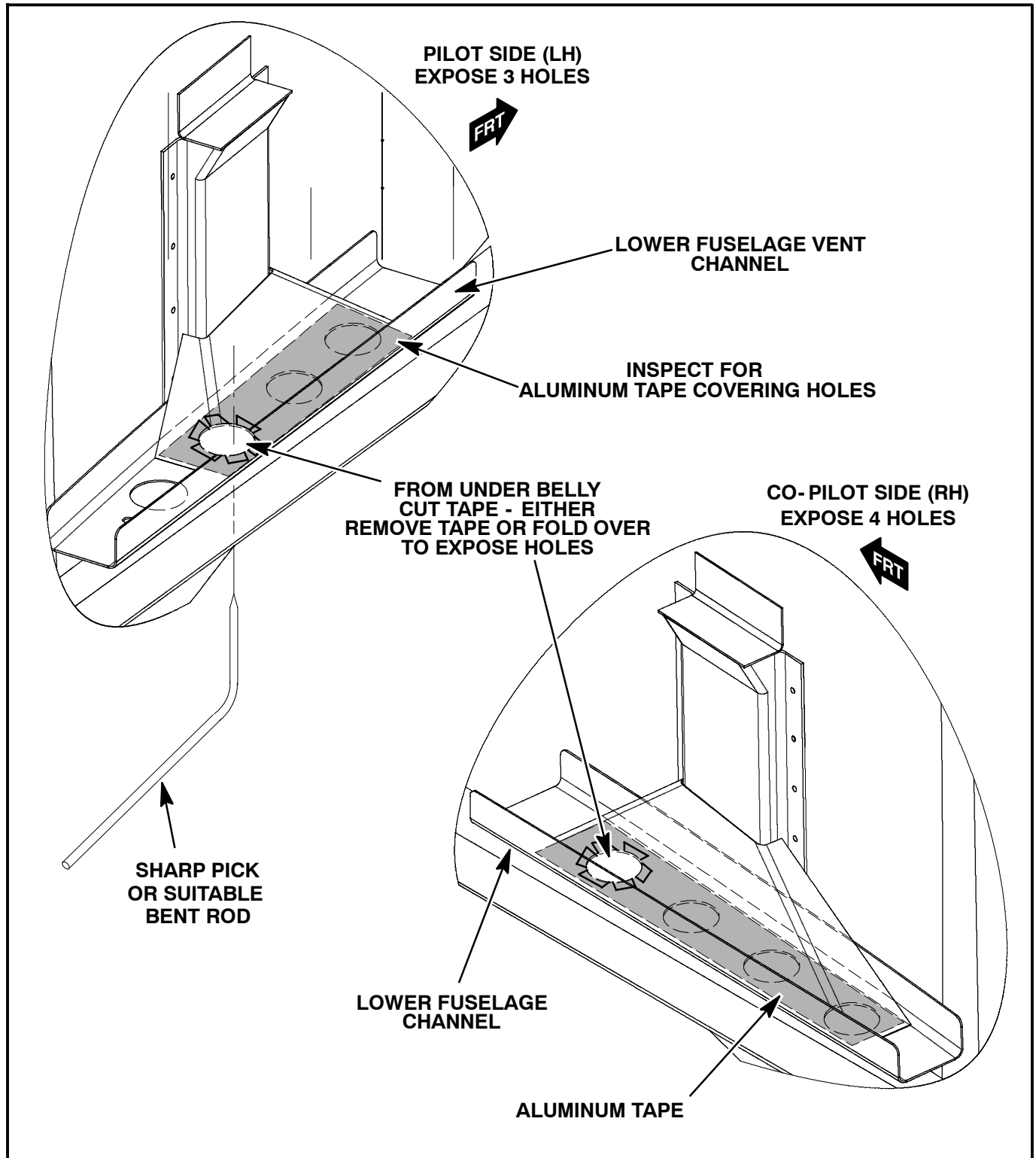

Figure SBM20-333-2 - REMOVING ALUMINUM TAPE FROM VENT HOLES



THIS BULLETIN DOES NOT CHANGE AIRCRAFT TYPE DESIGN

MOONEY INTERNATIONAL CORPORATION
KERRVILLE, TEXAS 78028 - FAX 830-257-4635

SERVICE (BULLETIN) (INSTRUCTION) NO. _____ HAS BEEN COMPLIED
WITH ON AIRCRAFT MODEL _____ SERIAL NUMBER _____

Tach. Time: _____ N-Number _____ (Reg. No.)
Owner: _____ Date of Compliance: _____
_____ Complied By: _____

Inspection Report: _____

Form 07-0001

PLACE
STAMP
HERE

MOONEY INTERNATIONAL CORPORATION
ATT'N: TECHNICAL SUPPORT
165 Al Mooney Road North
Kerrville, Texas 78028

SEND TO: Mooney International Corporation
165 Al Mooney Road North
Kerrville, TX 78028
FAX: (830) 257-4635 or EMAIL techpubs@mooney.com

Figure SB M20-333-3 - Compliance Card